



POWER PRESS



BHAGWATI ENGINEERS

'ANASUYA' presents to you a range of most technically advanced **Power press** with all latest features as per international standards.

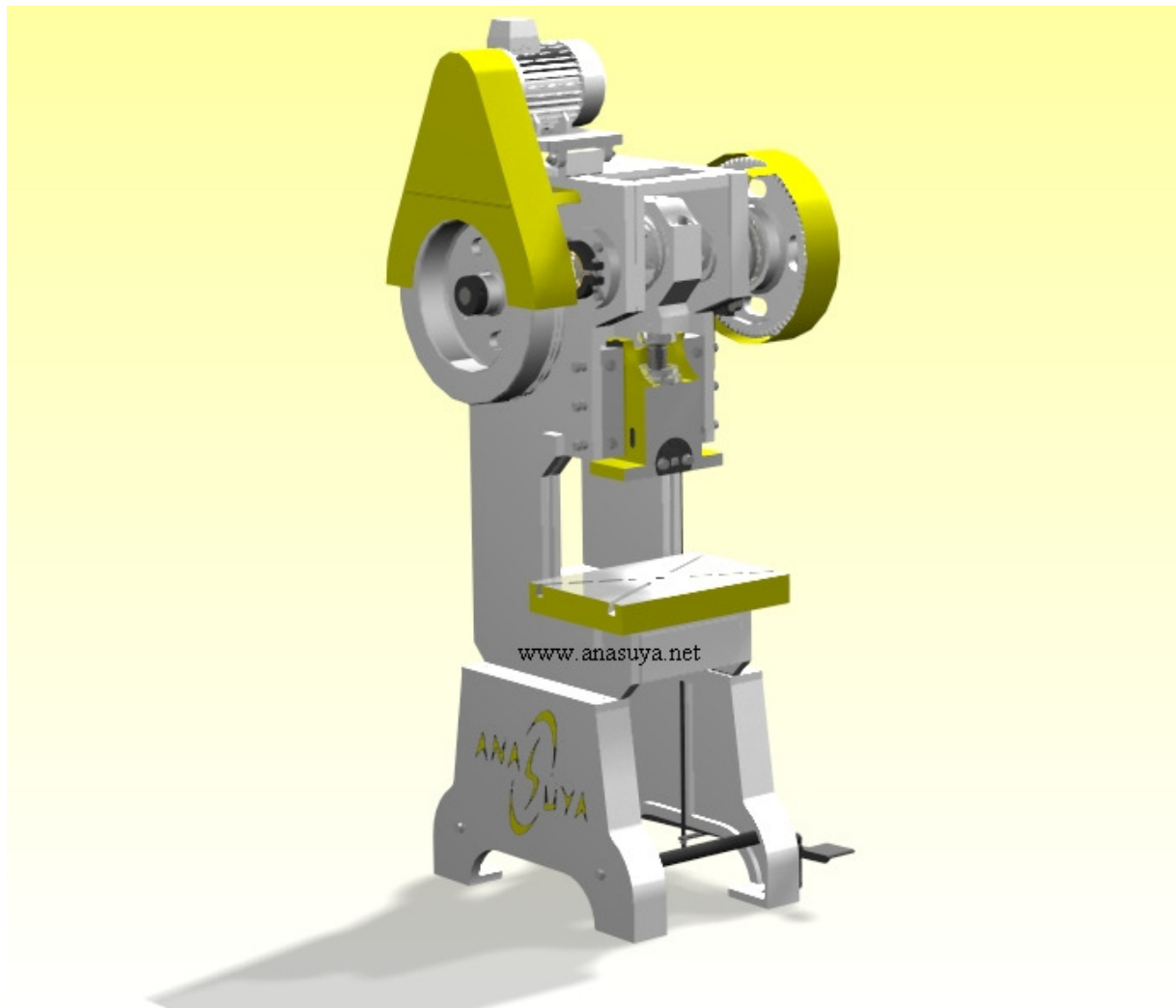

Features:

- » Low initial cost
- » Low tooling cost
- » Easy & Quick setting
- » Enormous versatility
- » Accurate repetition
- » User friendly
- » Easy maintenance
- » Standard spares, hence easy availability

GONDAL ROAD, NR. OCTROI POINT,
RAJKOT - 360 004. (GUJ.) INDIA,
tel : +91 - 281 - 2372576,
e-mail: bhagwatiengg@hotmail.com



ANASUYA Power Presses have been designed for continuous production & accuracy. The frame is of solid steel fabricated with suitable cross ribbing. The clutch is of rolling key type & gives continuous strokes for mass production. Crank shaft is made of special Alloy Steel and fitted in with Gun Metal bushes for smooth working and longer life. Table and ram are perfectly aligned to each other to obtain highly precision press operation.

MACHINE CONFIGURATION:

Sr. No.	Tonnage	STROKE ADJUSTMENT	SLIDE ADJ.	DIST BED TO RAM)	LENGTH & WIDTH OF BED)	HOLE IN BED	HOLE IN RAM	CRANK SHAFT DIAMETER	FLY WHEEL DIAMETER	STROKE PER MINUTE	H.P. REQUIRED	WEIGHT APPROX.
1	3	2-20	20	150	250 X 150	50	20	38	330	90	0.5/1440	200
2	5	6-25	20	150	350 X 175	62	25	51	356	80	0.5/1440	300
3	10	6-25	25	180	355 X 200	75	25	60	406	80	1/1440	450
4	15	10-38	25	205	432 X 255	89	32	70	457	75	1.5/1440	700
4	20	13-51	25	230	457 X 524	89	32	76	508	60	2/1440	900
5	30	13-51	25	266	560 X 355	102	38	83	560	55	3/1440	1100
6	50	13-76	40	290	660 X 406	127	50	95	762	50	5/1440	2350
7	75	13-102	50	330	711 X 508	178	50	115	762	50	7.5/1440	3500
8	100	13-115	60	381	813 X 558	190	55	127	813	45	10/1440	5000
9	150	13-127	60	410	914 X 610	203	55	140	915	40	15/1440	6000
10	200	13-152	70	432	965 X 660	215	63	158	1118	30	20/1440	9000
11	250	13-165	70	485	1067 X 711	216	63	165	1170	30	25/1440	11500

MODELS:

- » C-Frame
- » C-Frame inclinable type
- » H-Frame Pillar type
- » Cross Shaft Press
- » Geared drive
- » Un-geared Drive
- » Rigid Frame.



BHAGWATI ENGINEERS

Standard Accessories:

- » Motor Pulley
- » Clutch Key
- » Clutch Key Springs
- » Slide Adj. Spanner
- » Oil Cups for Lubrication Point
- » Knock-out System

Optional Accessories :

- » Centralized lubrication (hand pump)
- » Electricals & Motor
- » Stroke Counter
- » Foundation Bolt
- » Auto-feeder, De-coiler, Straightener

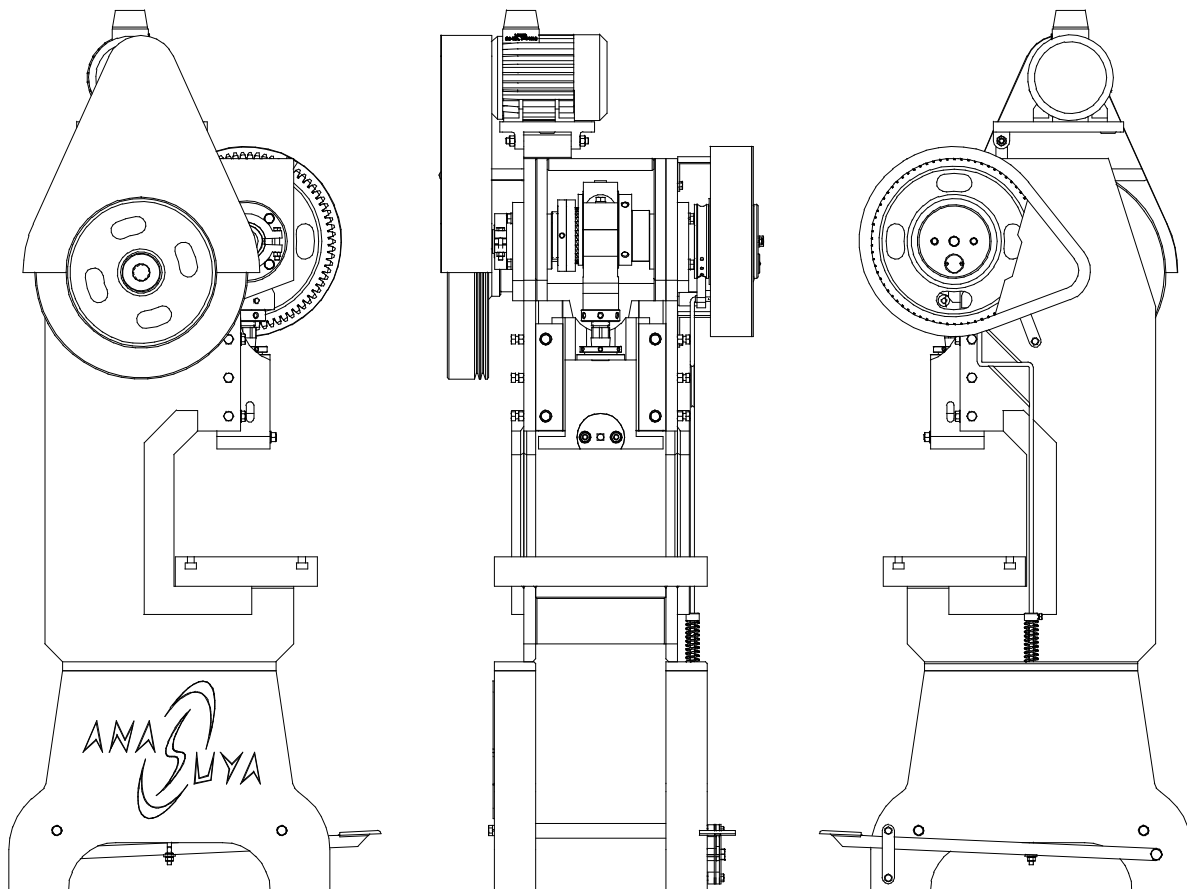

GONDAL ROAD, NR. OCTROI POINT,
RAJKOT - 360 004. (GUJ.) INDIA,
tel : +91 - 281 - 2372576,
e-mail: bhagwatiengg@hotmail.com